

Trunking Flex 31 - Notlicht Emergency lighting

51RF...2C

51RF...2S

51RF...D

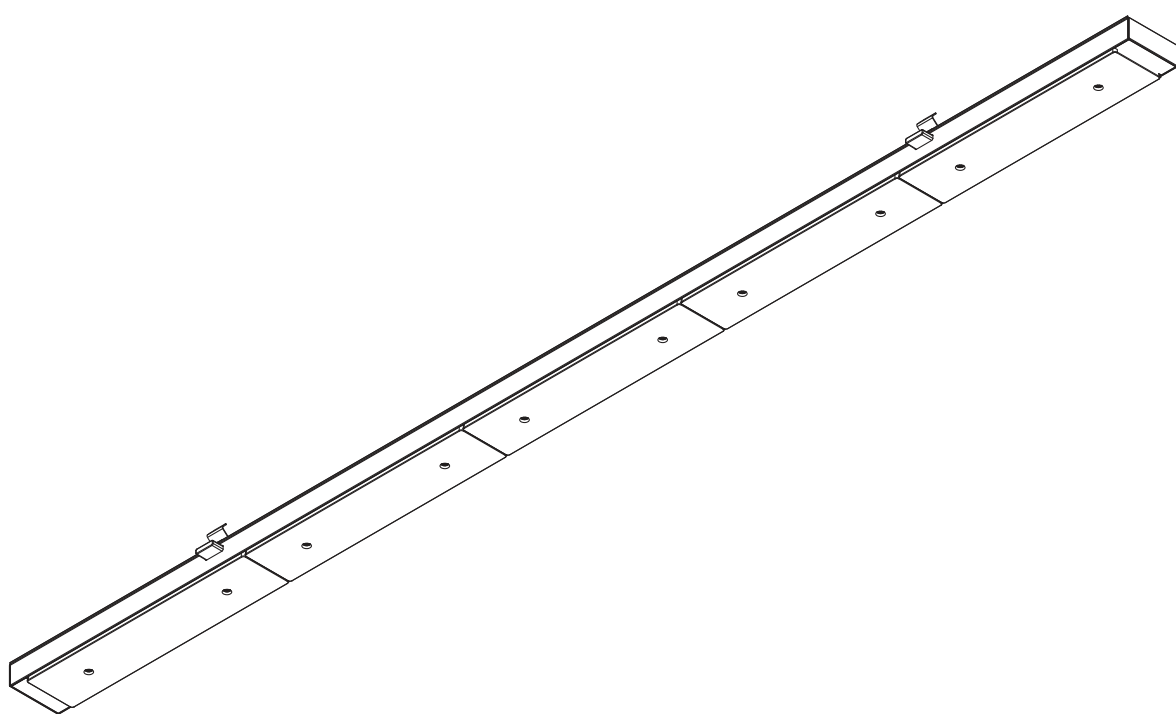

siteco

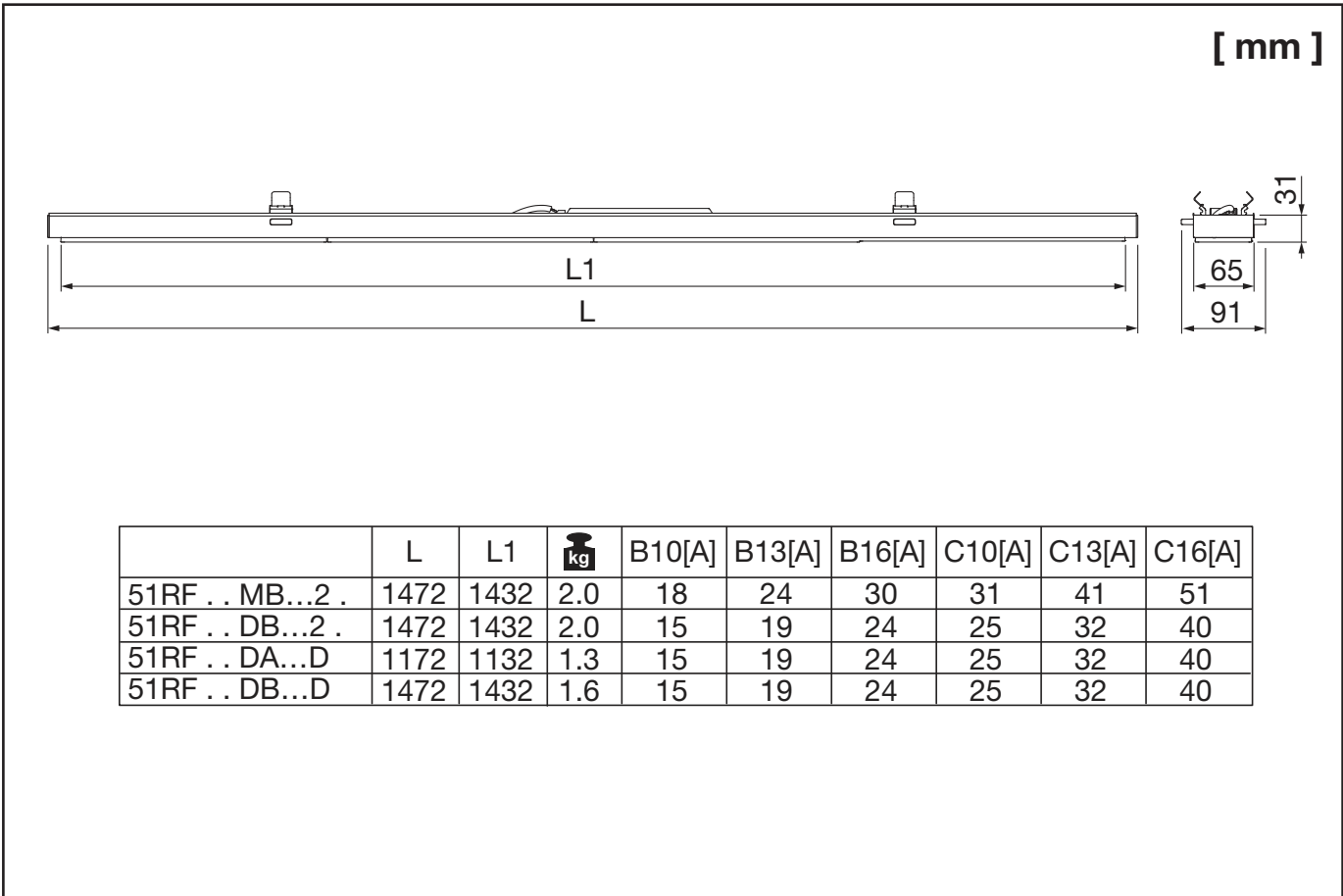
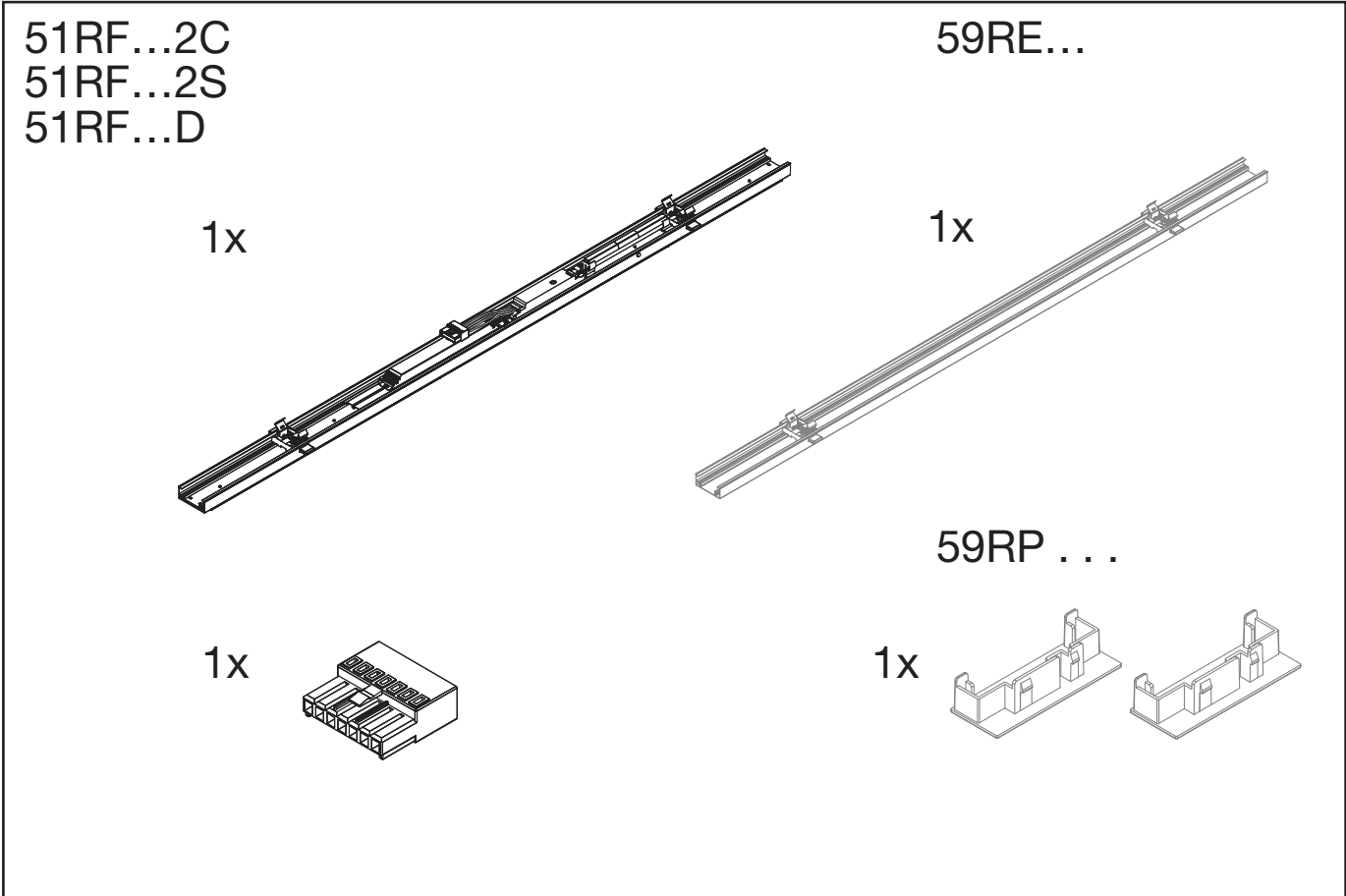

- 1 51RF...2C
- 51RF...2S
- 51RF...D

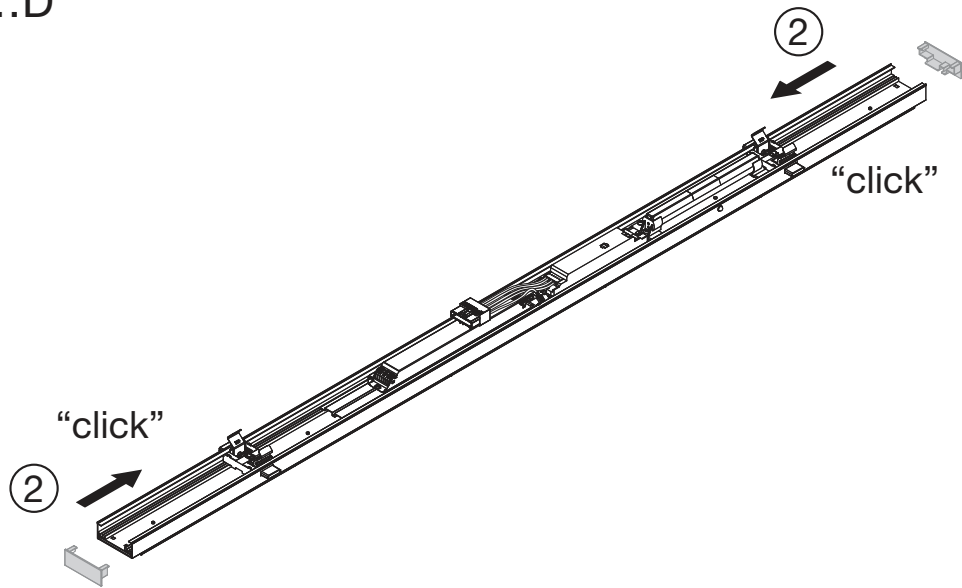

- 2 51RF...2C
- 51RF...2S
- 51RF...D

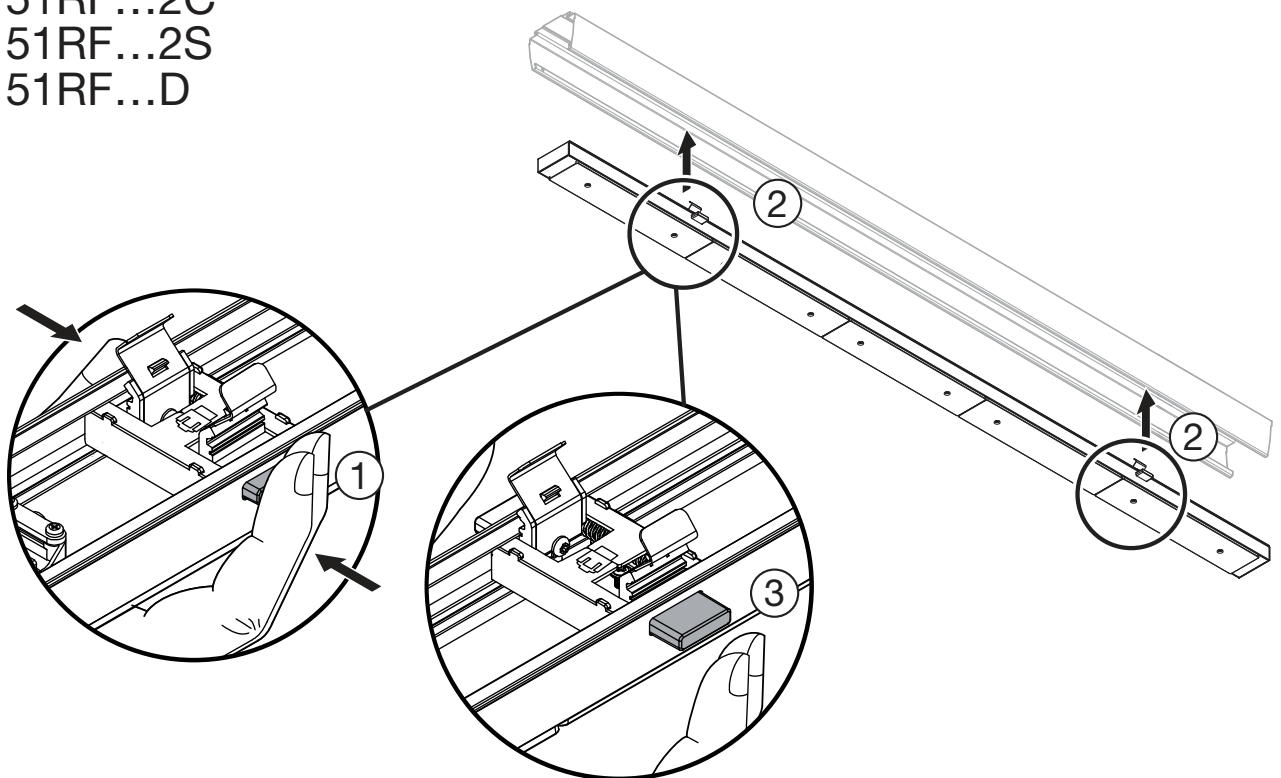

51RF . 4...2C
51RF . 4...2S
51RF . 4...D

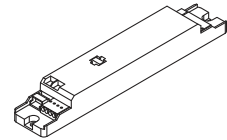
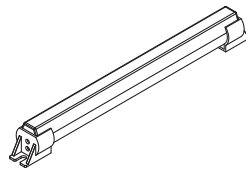
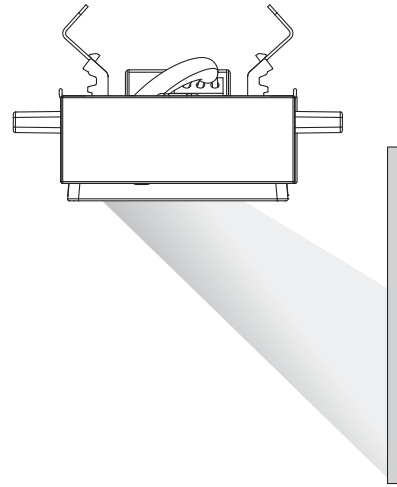
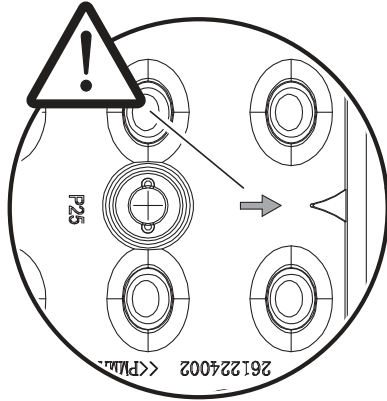

51RF ... 2C
Central Test



51RF ... 2S
Self Test



51RF...2C
51RF...2S

3.2V 4.5Ah LiFeP04
3h 2.3W

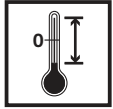

$t_a = +5...+40^\circ\text{C}$

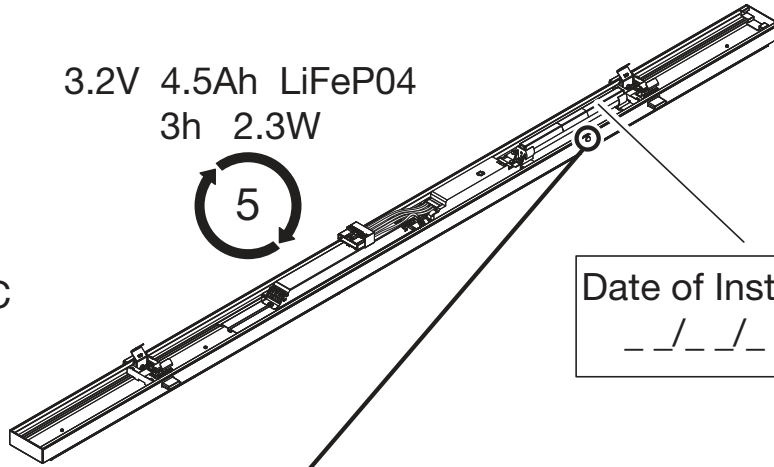

Date of Installation

___/___/___

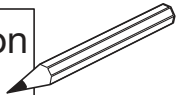

Systemstatus

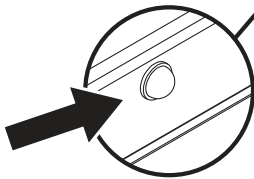

GN

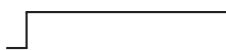

System OK
System OK

GN



Funktionstest läuft
Funktion test underway

wöchentlich
weekly

5sec

GN

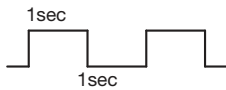

Betriebsdauertest läuft
Duration test underway

jährlich
yearly

$\geq 3h$

RD

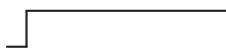

Lastfehler
I load failure

offener Schaltkreis/Kurzschluss/LED-Fehler
open circuit / short circuit / LED error

RD

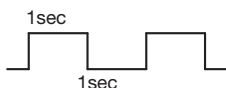

Akkufehler
Battery failure

keine / nicht ausreichende Kapazität,
falscher / defekter Akku
no / insufficient capacity, false / defective battery

RD



Ladefehler
Charging failure

falscher Ladestrom
Incorrect charging current

RD-GN



DC-Betrieb
DC mode

Akku-Betrieb
Battery operation

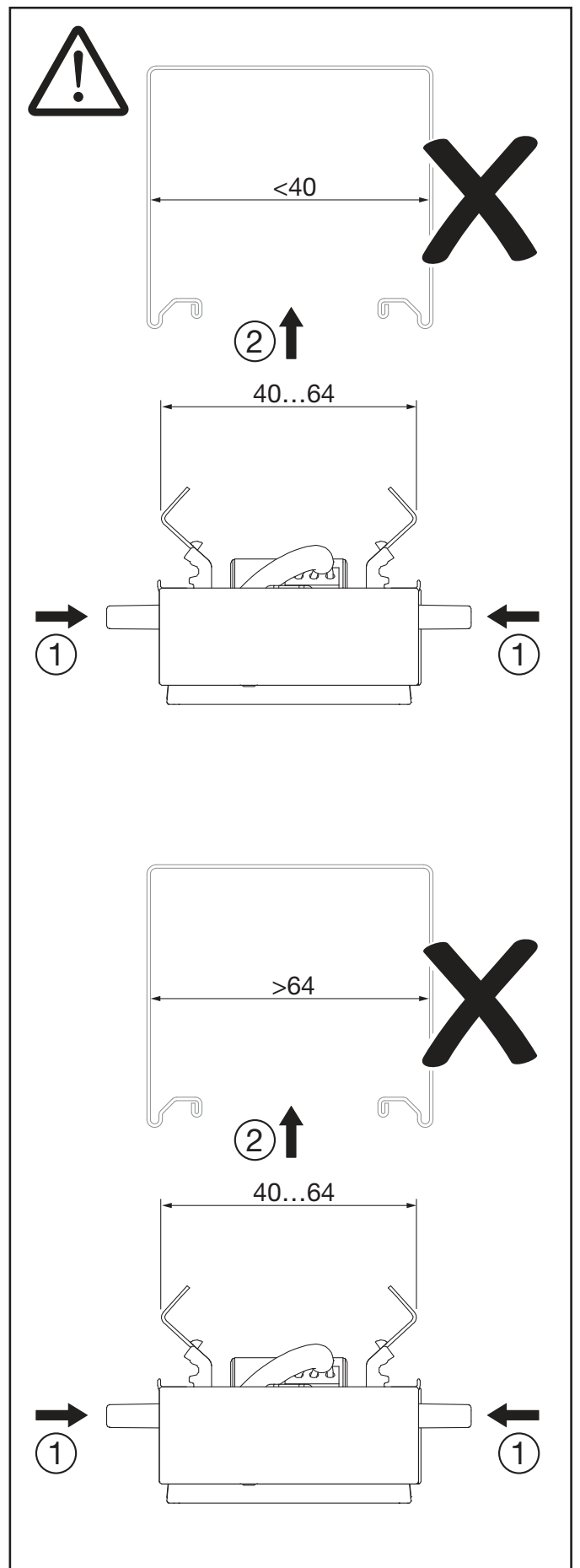
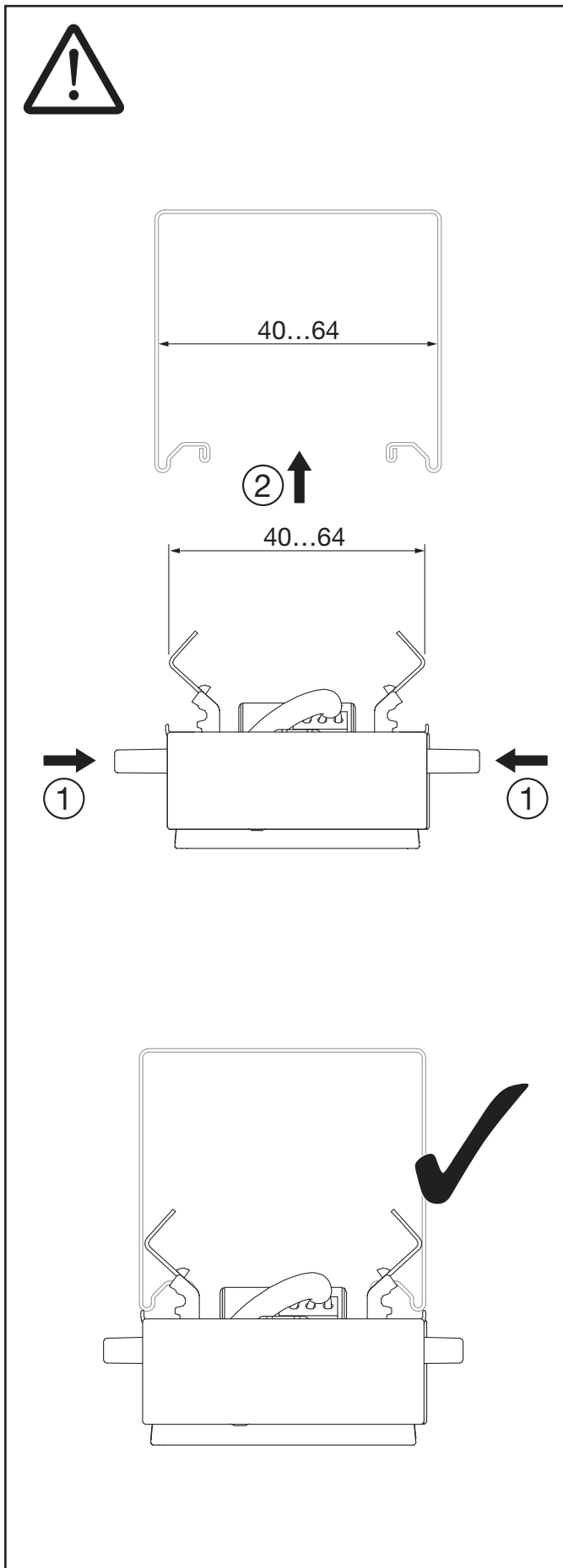

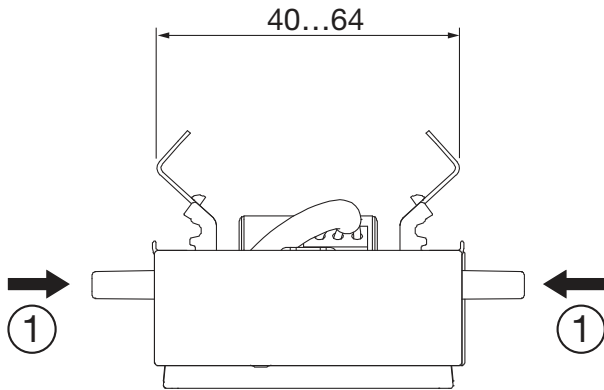
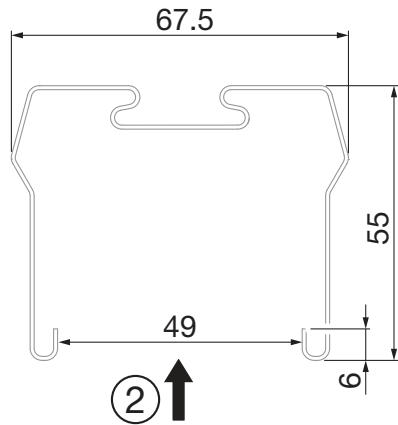

59RL0CD

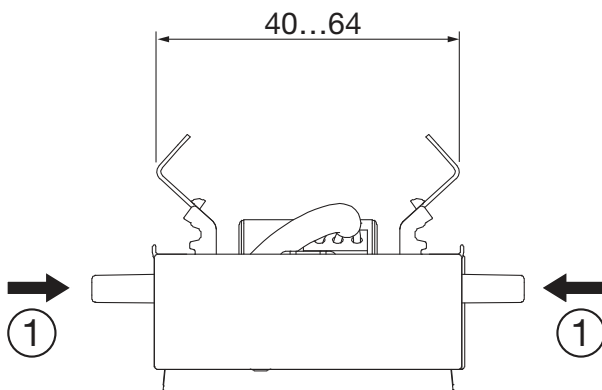
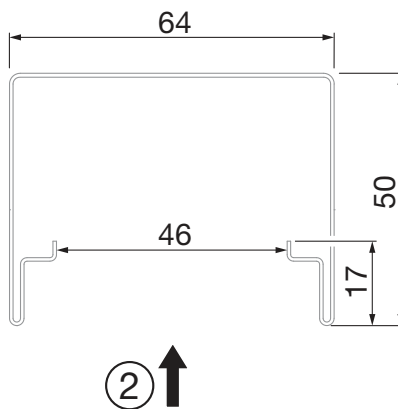
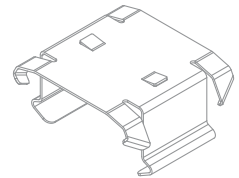

59RL0CR

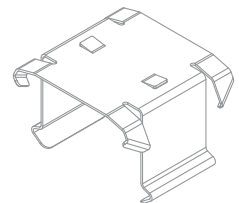

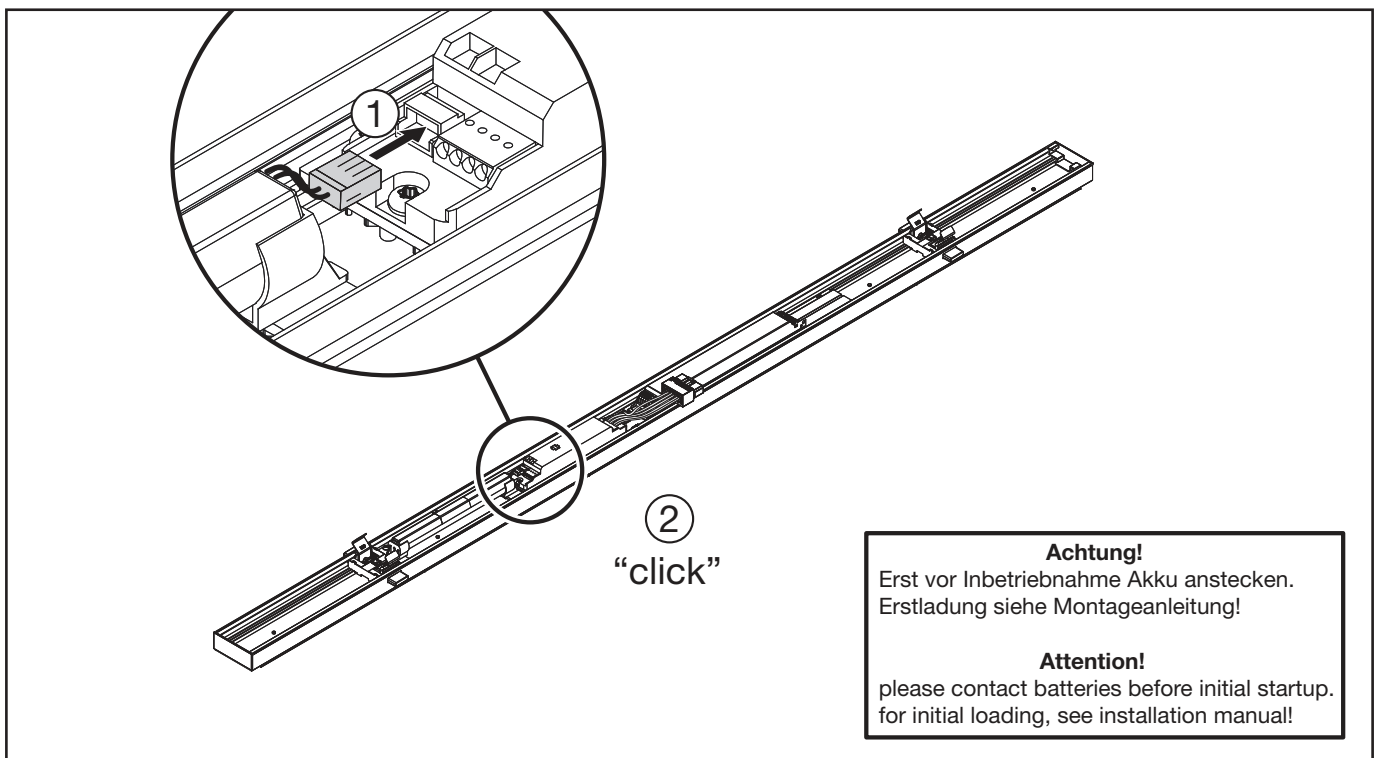
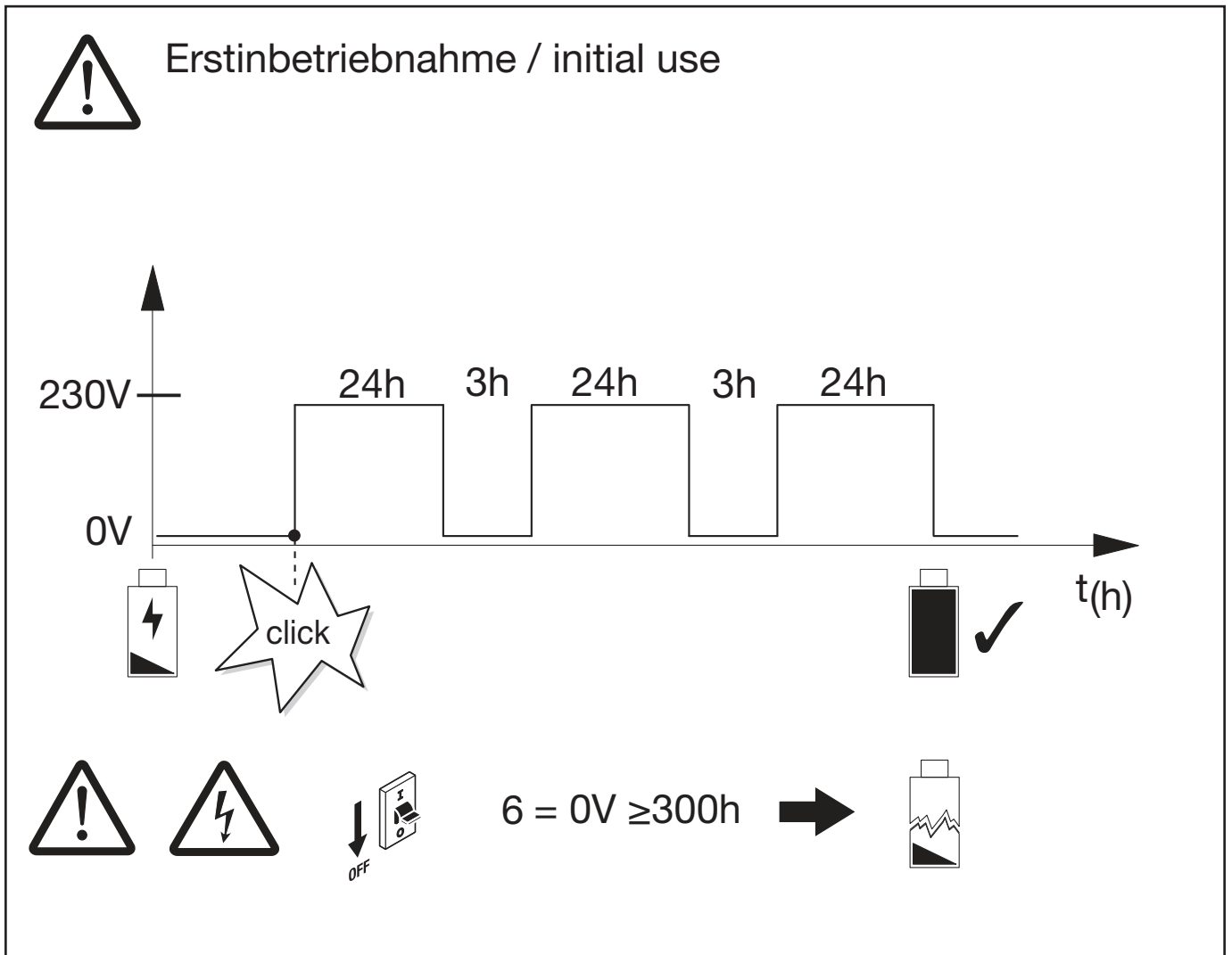

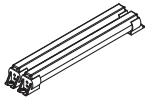

TRIDONIC
28002320

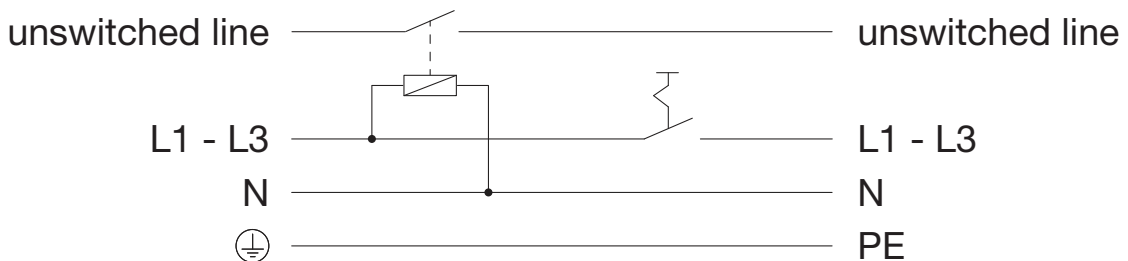
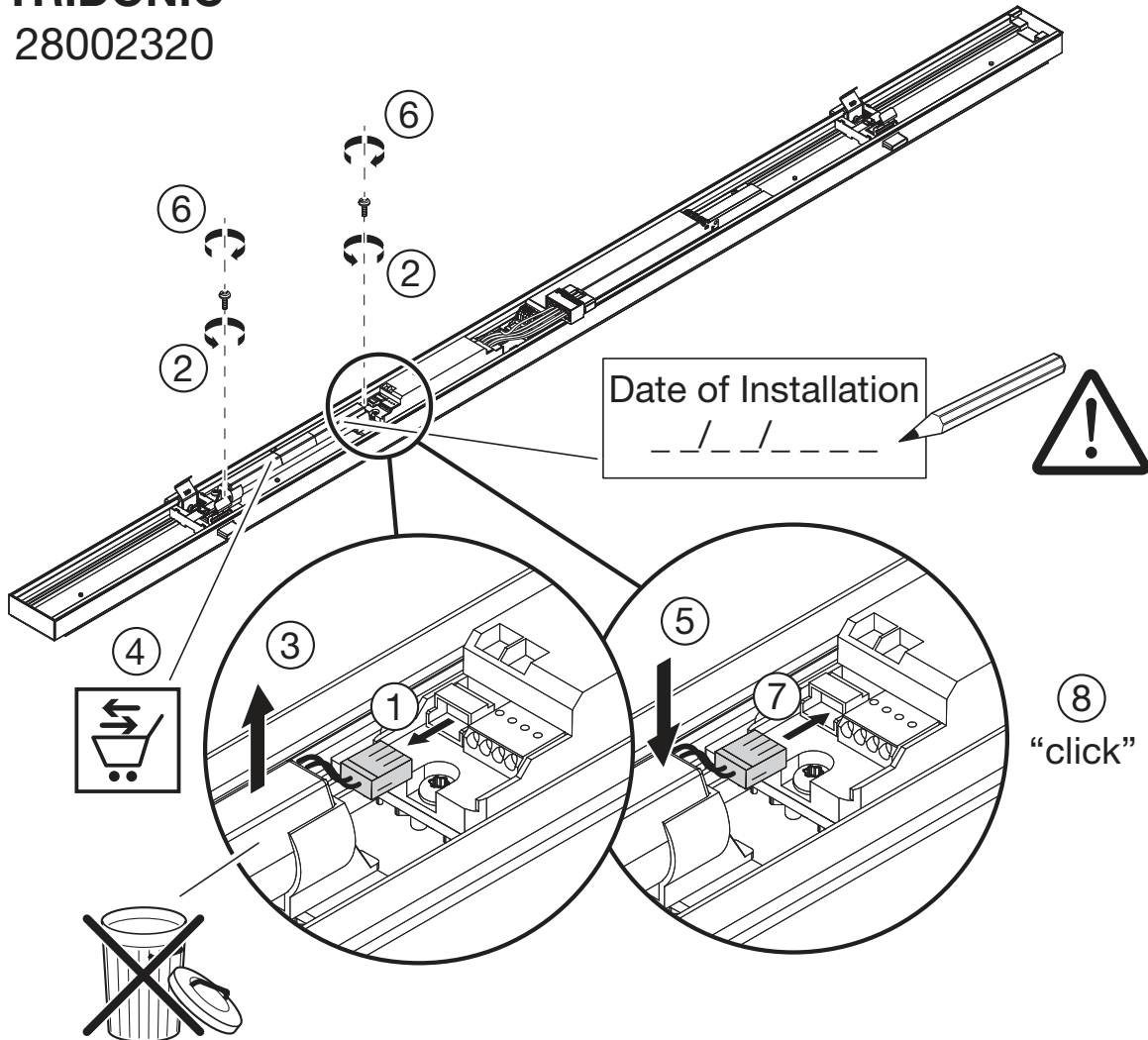

Die Verwendung unterschiedlicher Phasen für die geschaltete und ungeschaltete Phase ist erlaubt. Bei der Verwendung unterschiedlicher Phasen muss die ungeschaltete Phase zeitgleich mit der geschalteten ausfallen. Dieses Verhalten wird benötigt um eine korrekte Umschaltung in den Notbetrieb zu gewährleisten.

The use of different phases for switched line and unswitched line is allowed. When using different phases, the unswitched line must fail if the switched line fails. This is required to assure correct switching into emergency mode. It can be realised with a relay.

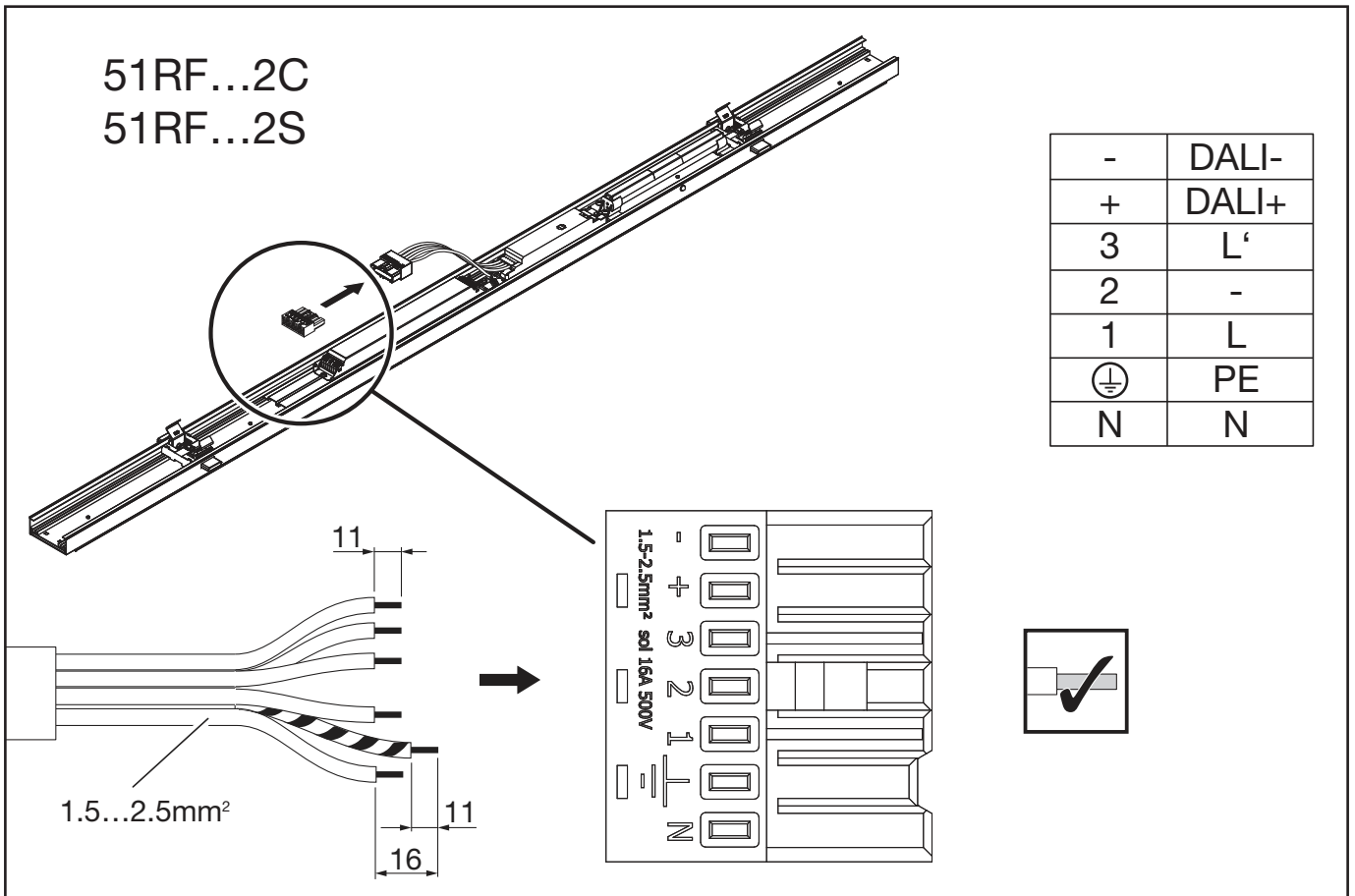
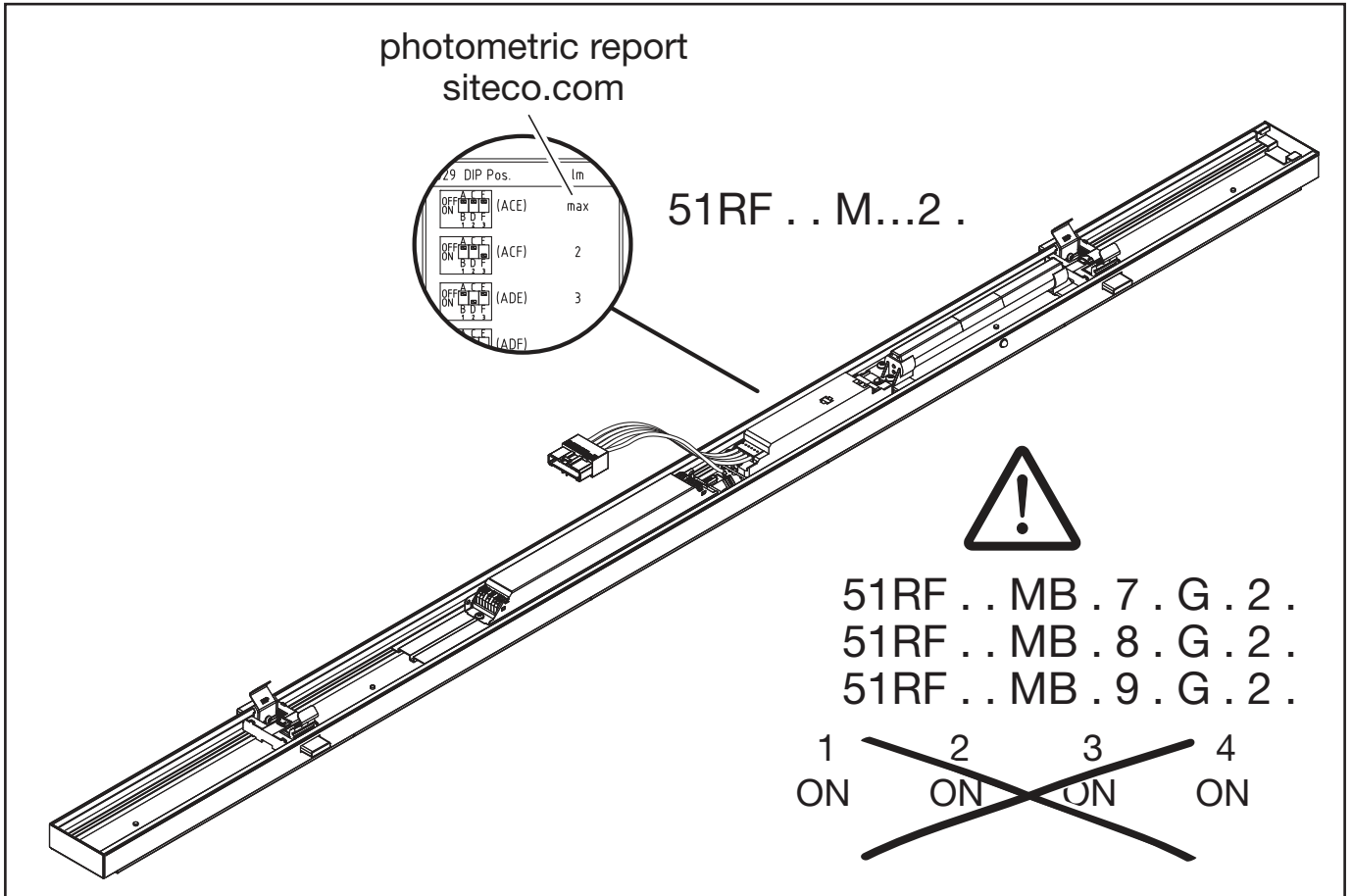

51RF...D

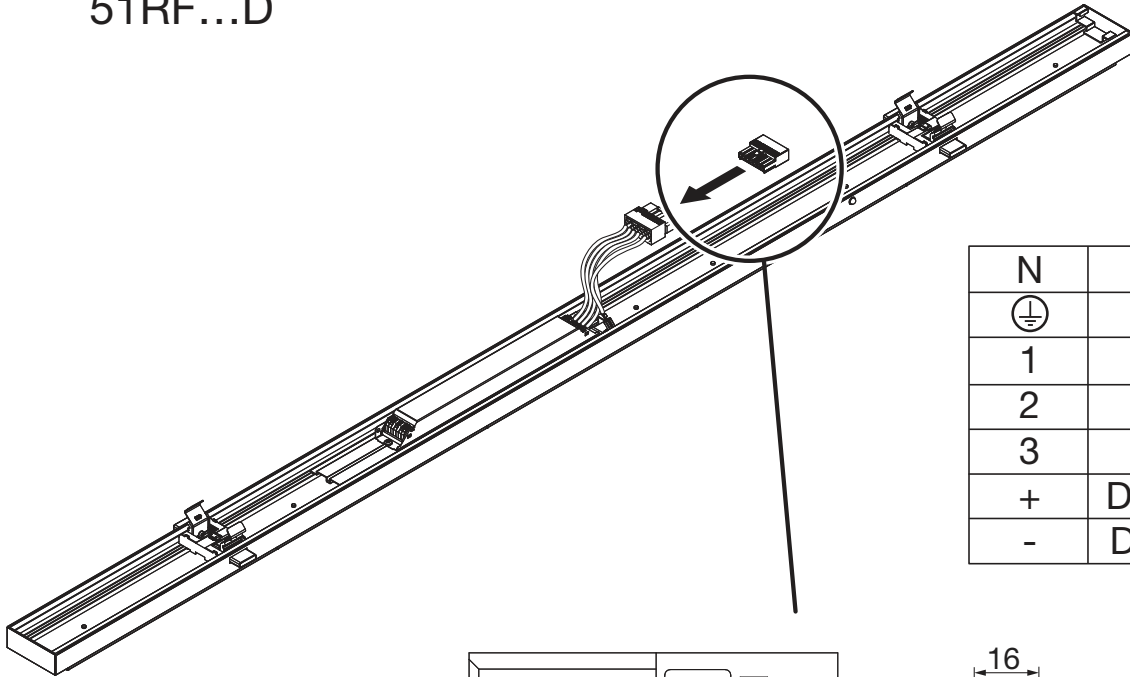

| | |
|---|-------|
| N | - |
| ⊕ | PE |
| 1 | - |
| 2 | EL |
| 3 | EN |
| + | DALI+ |
| - | DALI- |

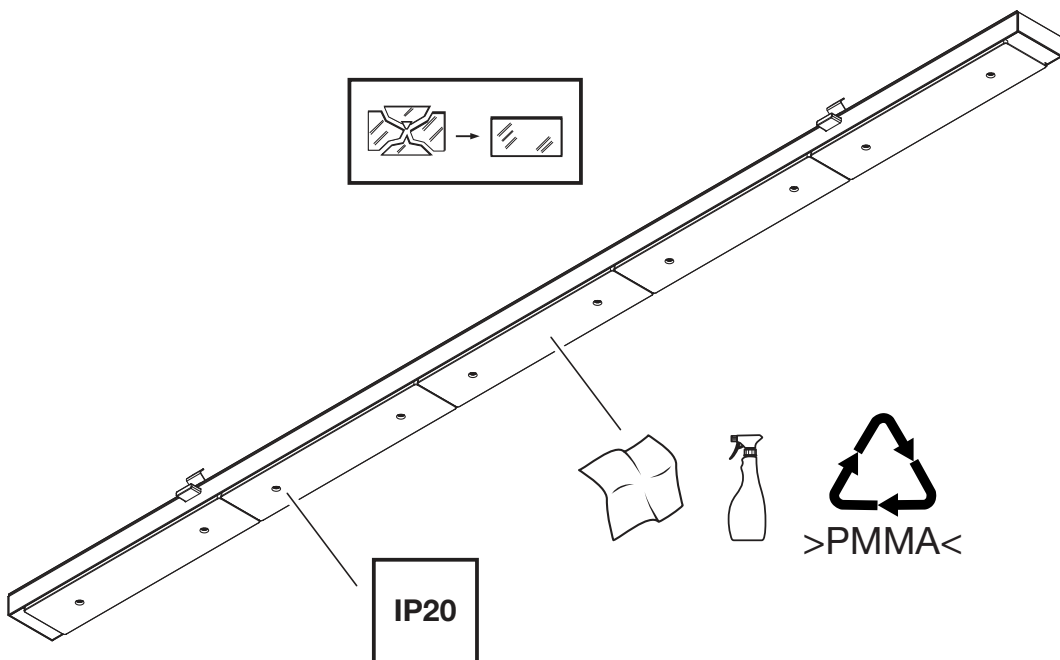
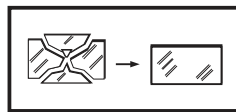
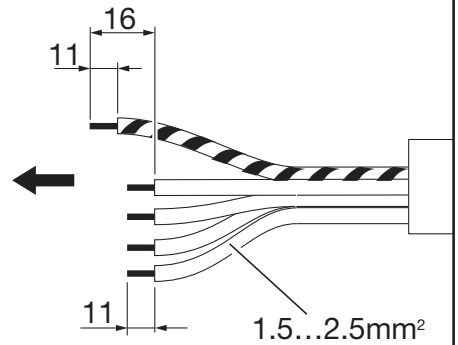
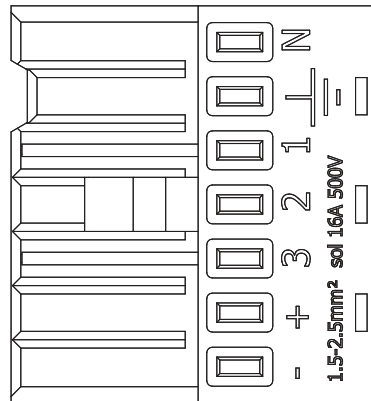

| | | |
|-------|---|--|
| | A | |
| 3000K | C | |
| 3500K | C | |
| 4000K | B | |
| 5000K | C | |
| 6500K | C | |

Dieses Produkt enthält eine Lichtquelle der Energieeffizienzklasse B-C.

This product contains a light source of energy efficiency class B-C.

Die Lichtquelle sowie das Betriebsgerät entsprechen den Anforderungen der Ökodesign-Verordnung (EU) 2019/2020, diese sind gemäß dieser Verordnung austauschbar.

The light source and control gear comply with the requirements of the Ecodesign Regulation (EU) 2019/2020 and are interchangeable in accordance with this regulation.

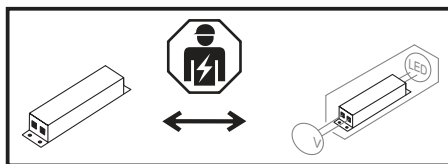
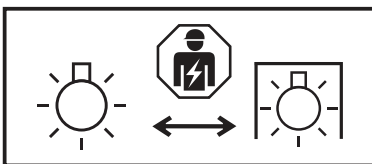
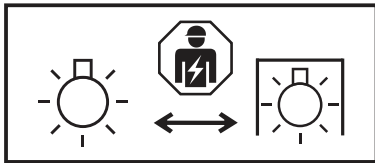

Die in dieser Leuchte enthaltene Lichtquelle und das Betriebsgerät dürfen nur durch den Hersteller, seinem Kundendienst oder einer ähnlich qualifizierten Person ausgewechselt werden. The light source and the control gear contained in this luminaire shall only be replaced by the manufacturer or their service agent or a skilled qualified person.

La source lumineuse et l'appareil de commande contenus dans ce luminaire ne peuvent être remplacés que par le fabricant, son service après-vente ou une personne qualifiée. La sorgente luminosa e l'alimentatore contenuti in questo apparecchio possono essere sostituiti solo dal costruttore, dal suo centro di assistenza o da personale qualificato. La fuente de luz y el equipo de control contenidos en esta luminaria solo deben ser reemplazados por el fabricante, su servicio técnico o una persona cualificada. A fonte de luz e o equipamento de controlo contidos nesta luminária só podem ser substituídos pelo fabricante, pelo seu serviço autorizado ou por pessoa qualificada. Η πηγή φωτός και το σύστημα ελέγχου που περιέχονται σε αυτό το φωτιστικό μπορούν να αντικατασταθούν μόνο από τον κατασκευαστή, τον εξουσιοδοτημένο τεχνικό του ή από κατάλληλα εκπαιδευμένο άτομο. De lichtbron en het voorschakelapparaat in dit armatuur mogen uitsluitend worden vervangen door de fabrikant, diens servicepartner of een vakbekwaam persoon. Ljuskällan och driftdonet i denna armatur får endast bytas av tillverkaren, dess servicepartner eller en fackkunnig person. Tämän valaisimen valonlähteen ja liitäntälaitteen saa vaihtaa vain valmistaja, sen huolto tai pätevä henkilö. Lyskilden og forkoblingen i denne armaturen skal kun skiftes av produsenten, hans servicepartner eller en kvalifisert person. Lyskilden og forkoblingen i dette armatur må kun udskiftes af producenten, dennes servicepartner eller en kvalificeret person. Světelný zdroj a předřadník v tomto svítidle smí vyměnit pouze výrobce, jeho servis nebo kvalifikovaná osoba. Источник света и пускорегулирующую аппаратуру в данном светильнике могут заменять только производитель, его сервисная служба или квалифицированное лицо. A világítóttestben lévő fényforrás és elötétet csak a gyártó, annak szervize vagy képzett személy cserélheti. Źródło światła i zasilacz znajdujące się w tej oprawie mogą być wymieniane wyłącznie przez producenta, jego serwis lub osobę wykwalifikowaną. Svetelný zdroj a predradník v tomto svetidle smie vymieňať len výrobca, jeho servis alebo kvalifikovaná osoba. Svetlobni vir in napajalnik v tej svetilki lahko zamenja le proizvajalec, njegov servis ali usposobljena oseba. Bu armatürdeki ışık kaynağı ve kontrol donanımı yalnızca üretici, yetkili servisi veya yetkin bir kişi tarafından değiştirilebilir. Izvor svetla i upravljački uređaj u ovoj svetiljci smiju zamjenjivati samo proizvođač, njegov servis ili kvalificirana osoba. Sursa de lumină și balastul conținute în acest corp de iluminat pot fi înlocuite doar de producător, de serviciul său autorizat sau de o persoană calificată. Светлинният източник и апаратът в това осветително тяло могат да се подменят само от производителя, неговия сервиз или квалифицирано лице. Selles valgustis olevat valgusalikid ja toiteplokkid võivad vahetada ainult tootja, tema hoolduspartner või kvalifitseeritud isik. Šiame šviestuve esantį šviesos šaltinį ir maitinimo įrenginį gali keisti tik gamintojas, jo servisas arba kvalifikuotas asmuo. Šā gaismekļa gaismas avotu ir vadības ierīci drīkst nomainīt tikai ražotājs, viņa serviss vai kvalificēta persona. Izvor svetlosti i upravljački uređaj u ovoj svetiljci smeju da zamene samo proizvođač, njegov servis ili kvalifikovano lice. Джерело світла та пускорегулювальний апарат у цьому світильнику можуть замінювати лише виробник, його сервіс або кваліфікована особа. Осы шамдағы жарық көзін және басқару құрылғысын тек өндіруші, оның сервистік өкілі немесе білікті адам ғана ауыстыра алады.



5MA69-271310_ae
19.02.2026 / KIN

Siteco GmbH
Georg-Simon-Ohm-Straße 50
83301 Traunreut, Germany
mail: technicalsupport@siteco.de
Phone: +49 8669 / 33-844
www.siteco.com