

# Lunis 21 - Anbau / Surface Mounted

ON / OFF - Multilumen

DALI 2 - Multilumen

DALI DT8 - Tunable White

51DB . . . D2 . . 1D - Lunis 21 L

51DB . . . F2 . . 1D - Lunis 21 XL

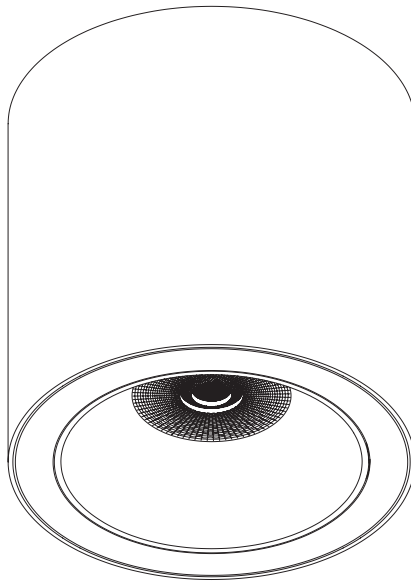

**siteco**

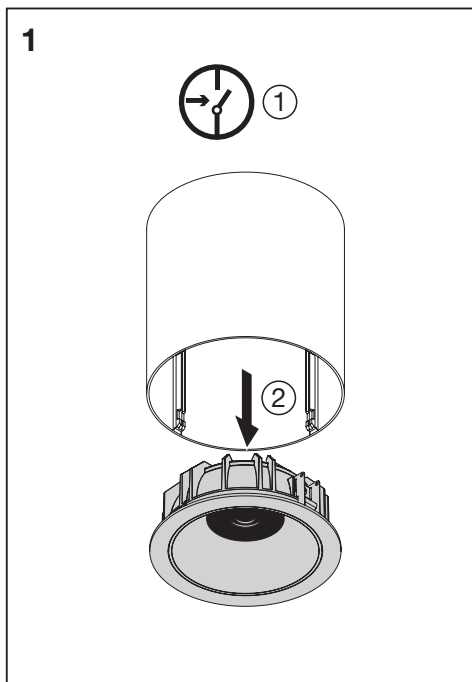
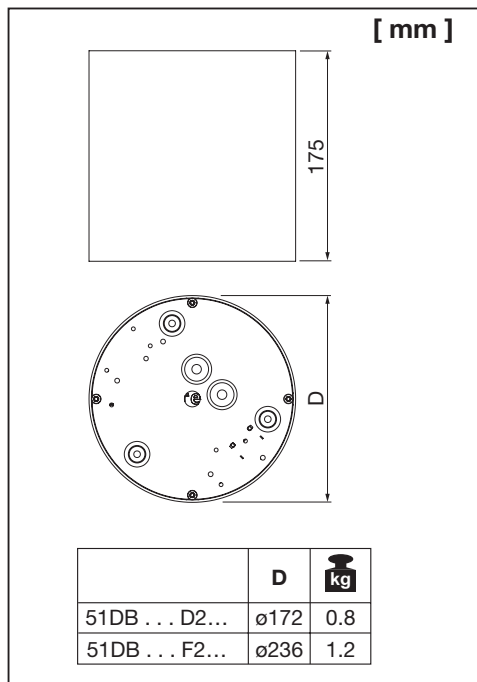

	DALI DT8 Tunable white		 1 2 ... n	
	B16 [A]	C16 [A]	B16 [A]	C16 [A]
51DB .. TD ... 1D	n ≤ 53	n ≤ 85		
51DB .. TF ... 1D	n ≤ 53	n ≤ 85		

  

ON/OFF	 1 2 ... n	
	B16 [A]	C16 [A]
51DB .. MD ... 1D	n ≤ 16	n ≤ 27
51DB .. MF ... 1D	n ≤ 16	n ≤ 27

DALI	 1 2 ... n	
	B16 [A]	C16 [A]
51DB .. ED ... 1D	n ≤ 40	n ≤ 60
51DB .. EF ... 1D	n ≤ 40	n ≤ 60



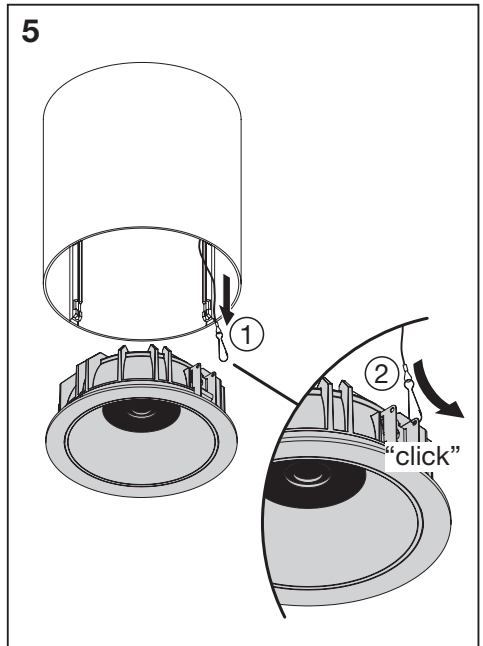
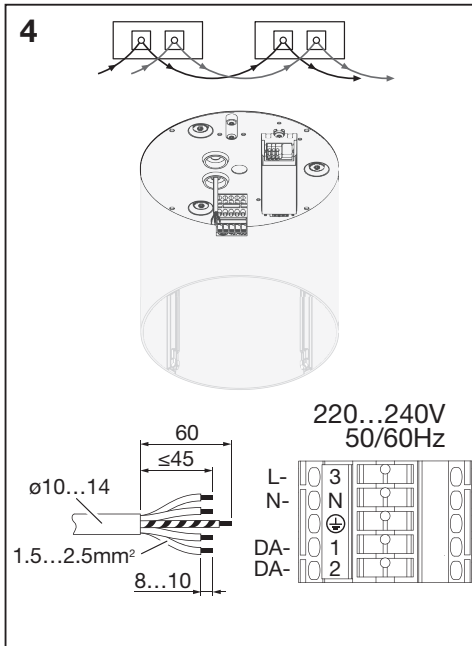
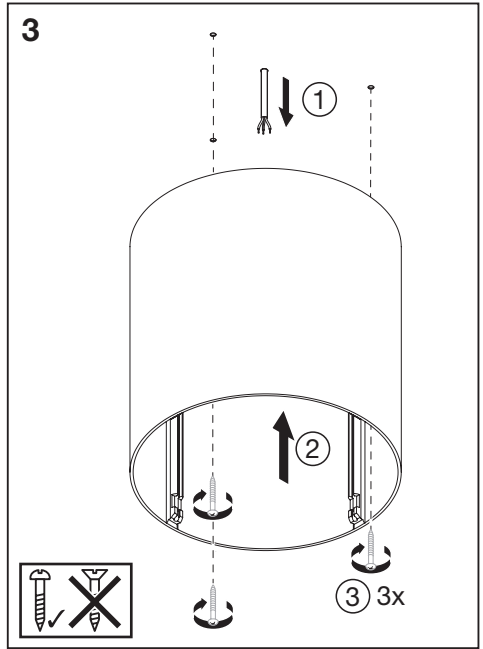
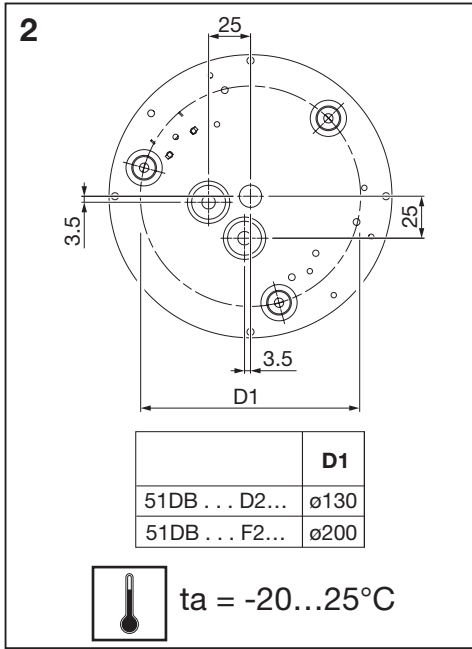

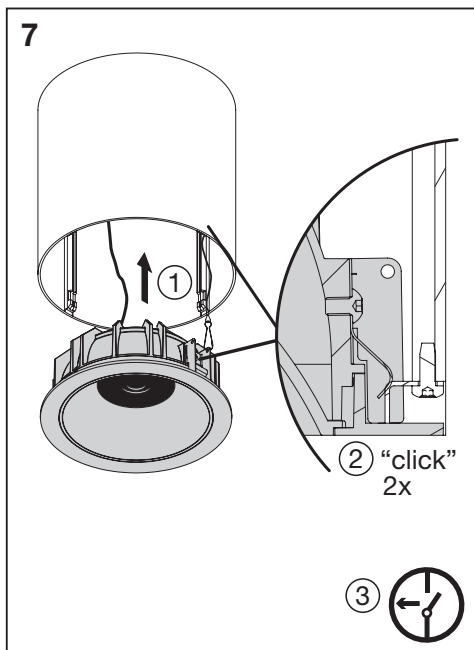
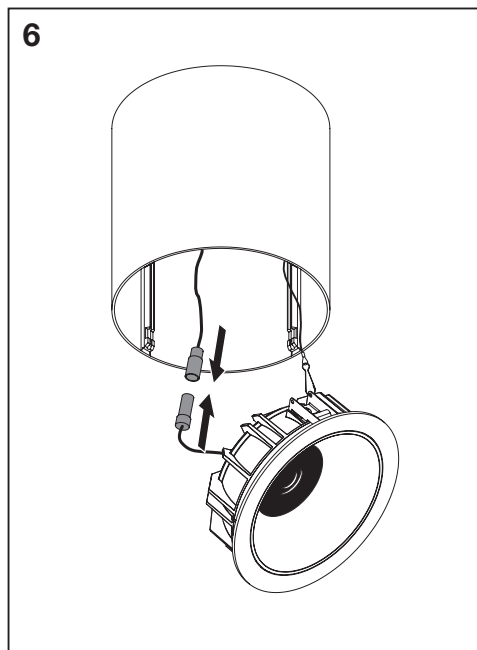
ON/OFF - Multilumen  
 DALI 2 - Multilumen  
 DALI DT8 - Tunable White

Central supply

Lunis L / XL

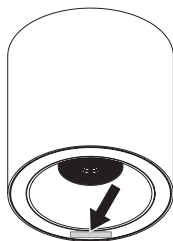

2x 

Z	1	E	
---	---	---	--

No central supply





=

## Lunis 21 L

### 51DB .. MD... (Multilumen ON/OFF)

mA	1	2	3	K	51DB .3MD .1... High-gloss aluminum Medium beam		51DB .3MD .3... White Medium beam		51DB .3MD .2... Black Medium beam		51DB .3MD .4... Aluminum matte Medium beam		51DB .3MD .5... Diffuse coverage Opal	
					lm	W	lm	W	lm	W	lm	W	lm	W
350	OFF	OFF	OFF	3000K	2110	13.3	2140	13.3	1940	13.3	1990	13.3	1880	13.3
500	OFF	ON	ON	3000K	2970	18.9	3020	18.9	2740	18.9	2810	18.9	2650	18.9
600	ON	OFF	ON	3000K	3530	22.8	3580	22.8	3260	22.8	3340	22.8	3150	22.8
350	OFF	OFF	OFF	4000K	2200	13.3	2230	13.3	2030	13.3	2080	13.3	1960	13.3
500	OFF	ON	ON	4000K	3100	18.9	3140	18.9	2860	18.9	2930	18.9	2760	18.9
600	ON	OFF	ON	4000K	3580	22.8	3730	22.8	3390	22.8	3480	22.8	3280	22.8

### 51DB .. ED... (Multilumen DALI)

mA	1	2	3	K	51DB .3ED .1... High-gloss aluminum Medium beam		51DB .3ED .3... White Medium beam		51DB .3ED .2... Black Medium beam		51DB .3ED .4... Aluminum matte Medium beam		51DB .5ED .5... Diffuse coverage Opal	
					lm	W	lm	W	lm	W	lm	W	lm	W
350	OFF	OFF	ON	3000K	2110	14.3	2140	14.3	1940	14.3	1990	14.3	1880	14.3
500	OFF	ON	ON	3000K	2970	20.2	3020	20.2	2740	20.2	2810	20.2	2650	20.2
600	ON	OFF	ON	3000K	3530	23.8	3580	23.8	3260	23.8	3340	23.8	3350	23.8
350	OFF	OFF	ON	4000K	2200	14.3	2230	14.3	2030	14.3	2080	14.3	1960	14.3
500	OFF	ON	ON	4000K	3100	20.2	3340	20.2	2860	20.2	2930	20.2	2730	20.2
600	ON	OFF	ON	4000K	3680	23.8	3730	23.8	3390	23.8	3480	23.8	3280	23.8



## Lunis 21 XL

### 51DB .. MF... (Multilumen ON/OFF)

mA	51DB . 3MF . 1... High-gloss aluminum Medium beam			51DB . 3MF . 3... White Medium beam			51DB . 3MF . 2... Black Medium beam			51DB . 3MF . 4... Aluminum matte Medium beam			51DB . 3MF . 5... Diffuse coverage Opal		
	1	2	3	Im	W	lm	Im	W	lm	Im	W	lm	W	lm	W
400	OFF	OFF	ON	2450	15.1	2480	15.1	2260	15.1	2370	15.1	2120	15.1	2120	15.1
500	OFF	ON	ON	3030	18.9	3080	18.9	2800	18.9	3010	18.9	2620	18.9	2620	18.9
600	ON	OFF	ON	3600	22.8	3650	22.8	3320	22.8	3490	22.8	3120	22.8	3120	22.8
400	OFF	OFF	ON	2550	15.1	2590	15.1	2350	15.1	2530	15.1	2210	15.1	2210	15.1
500	OFF	ON	ON	3160	18.9	3210	18.9	2910	18.9	3130	18.9	2730	18.9	2730	18.9
600	ON	OFF	ON	3750	22.8	3810	22.8	3460	22.8	3640	22.8	3250	22.8	3250	22.8

### 51DB .. EF... (Multilumen DALI)

mA	51DB . 3EF . 1... High-gloss aluminum Medium beam			51DB . 3EF . 3... White Medium beam			51DB . 3EF . 2... Black Medium beam			51DB . 3EF . 4... Aluminum matte Medium beam			51DB . 3EF . 5... Diffuse coverage Opal		
	1	2	3	Im	W	lm	Im	W	lm	Im	W	lm	W	lm	W
400	OFF	OFF	OFF	2450	16.2	2480	16.2	2260	16.2	2370	16.2	2120	16.2	2120	16.2
500	OFF	ON	ON	3030	20.2	3080	20.2	2800	20.2	3010	20.2	2620	20.2	2620	20.2
600	ON	OFF	ON	3600	23.8	3650	23.8	3320	23.8	3490	23.8	3120	23.8	3120	23.8
400	OFF	OFF	OFF	2550	16.2	2590	16.2	2350	16.2	2530	16.2	2210	16.2	2210	16.2
500	OFF	ON	ON	3160	20.2	3210	20.2	2910	20.2	3130	20.2	2730	20.2	2730	20.2
600	ON	OFF	ON	3750	23.8	3810	23.8	3460	23.8	3640	23.8	3250	23.8	3250	23.8



Possible  
ML-settings



Photometric report  
[siteco.com](http://siteco.com)

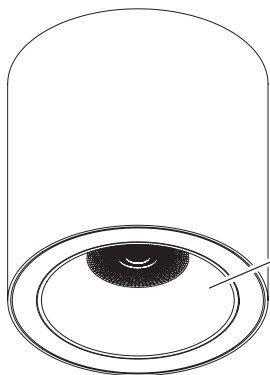

51DB . . . . . D . .	
51DB . . . . . B . .	
51DB . . T . . . . . D	

Dieses Produkt enthält eine Lichtquelle der Energieeffizienzklasse B, C oder E.  
This product contains a light source of energy efficiency class B, C or E.

Die Lichtquelle sowie das Betriebsgerät entsprechen den Anforderungen der Ökodesign-Verordnung (EU) 2019/2020, diese sind gemäß dieser Verordnung austauschbar.

The light source and control gear comply with the requirements of the Ecodesign Regulation (EU) 2019/2020 and are interchangeable in accordance with this regulation.

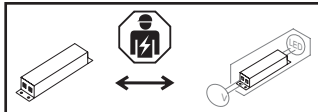
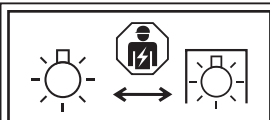
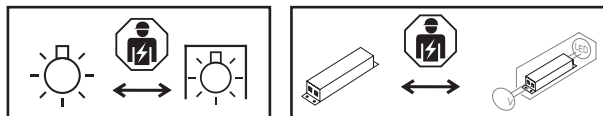

Ⓢ Die in dieser Leuchte enthaltene Lichtquelle und das Betriebsgerät dürfen nur durch den Hersteller, seinem Kundendienst oder einer ähnlich qualifizierten Person ausgewechselt werden. Ⓢ The light source and the controlgear contained in this luminaire shall only be replaced by the manufacturer or their service agent or a skilled qualified person.

Ⓢ La source lumineuse et l'appareil de commande contenus dans ce luminaire ne peuvent être remplacés que par le fabricant, son service après-vente ou une personne qualifiée. Ⓢ La sorgente luminosa e l'alimentatore contenuti in questo apparecchio possono essere sostituiti solo dal costruttore, dal suo centro di assistenza o da personale qualificato. Ⓢ La fuente de luz y el equipo de control contenidos en esta luminaria solo deben ser reemplazados por el fabricante, su servicio técnico o una persona cualificada. Ⓢ A fonte de luz e o equipamento de contro contidos nesta luminária só podem ser substituídos pelo fabricante, pelo seu serviço autorizado ou por pessoa qualificada. Ⓢ Η πηγή φωτός και το σύστημα ελέγχου που περιέχονται σε αυτό το φωτιστικό μπορούν να αντικατασταθούν μόνο από τον κατασκευαστή, τον εξουσιοδοτημένο τεχνικό του ή από κατάλληλα εκπαιδευμένο άτομο. Ⓢ De lichtbron en het voorschakelapparaat in dit armatuur mogen uitsluitend worden vervangen door de fabrikant, diens servicepartner of een vakbekwaam persoon. Ⓢ Ljuskällan och driftdonet i denna armatur får endast bytas av tillverkaren, dess servicepartner eller en fackkunnig person. Ⓢ Tämän valaisimen valonlähteen ja liitäntälaitteen saa vaihtaa vain valmistaja, sen huolto tai pätevä henkilö. Ⓢ Lyskilden og forkoblingen i denne armaturen skal kun skiftes af producenten, dennes servicepartner eller en kvalificeret person. Ⓢ Svetelný zdroj a predradník v tomto svítidle smí vyměnit pouze výrobce, jeho servis nebo kvalifikovaná osoba. Ⓢ Источник света и пускорегулирующую аппаратуру в данном светильнике могут заменять только производитель, его сервисная служба или квалифицированное лицо. Ⓢ A világítótésben lévő fényforrást és előtétet csak a gyártó, annak szervize vagy képzett személy cserélheti. Ⓢ Zródło światła i zasilacz znajdujące się w tej oprawie mogą być wymieniane wyłącznie przez producenta, jego serwis lub osobę wykwalifikowaną. Ⓢ Svetelný zdroj a predradník v tomto svietidle smie vymieňať len výrobca, jeho servis alebo kvalifikovaná osoba. Ⓢ Svetlobni vir in napajalnik v tej svetilki lahko zamenja le proizvajalec, njegov servis ali usposobljena oseba. Ⓢ Bu armatürdeki ışık kaynağı ve kontrol donanımı yalnızca üretici, yetkili servisi veya yetkin bir kişi tarafından değiştirilebilir. Ⓢ Izvor svetla i upravljački uređaj u ovoj svetiljci smiju zamjenjivati samo proizvođač, njegov servis ili kvalificirana osoba. Ⓢ Sursa de lumină și balastul conținute în acest corp de iluminat pot fi înlocuite doar de producător, de serviciul său autorizat sau de o persoană calificată. Ⓢ Светлинният източник и апаратът в това осветително тяло могат да се подменят само от производителя, неговия сервис или квалифицирано лице. Ⓢ Selles valgustus olevat valgusalikkat ja toiteplokki võib vahetada ainult tootja, tema hoolduspartner või kvalifitseeritud isik. Ⓢ Siamo svestuave esantj šviesos šaltinį ir maitinimo įrenginį gali keisti tik gamintojas, jo servisas arba kvalifikuotas asmuo. Ⓢ Šā gaismekļa gaismas avotu i vadības ierīci drīkst nomainīt tikai ražotājs, viņa serviss vai kvalificēta persona. Ⓢ Izvor svetlosti i upravljački uređaj u ovoj svetiljci smeju da zamene samo proizvođač, njegov servis ili kvalificovano lice. Ⓢ Джерело світла та пускорегулювальний апарат у цьому світільнику можуть замінювати лише виробник, його сервіс або кваліфікована особа. Ⓢ Осы шамдағы жарық көзін және басқару құрылғысын тек өндіруші, оның сервистік өкілі немесе білікті адам ғана ауыстыра алады.



5MA63-270772\_aa  
03.02.2026 / PZ

Siteco GmbH  
Georg-Simon-Ohm-Straße 50  
83301 Traunreut, Germany  
mail: technicalsupport@siteco.de  
Phone: +49 8669 / 33-844  
www.siteco.com