

Licross Spot 21

51SL...C

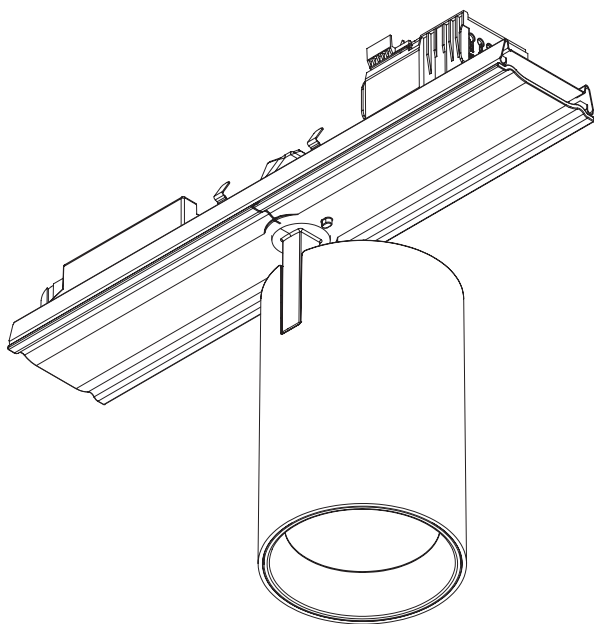

siteco

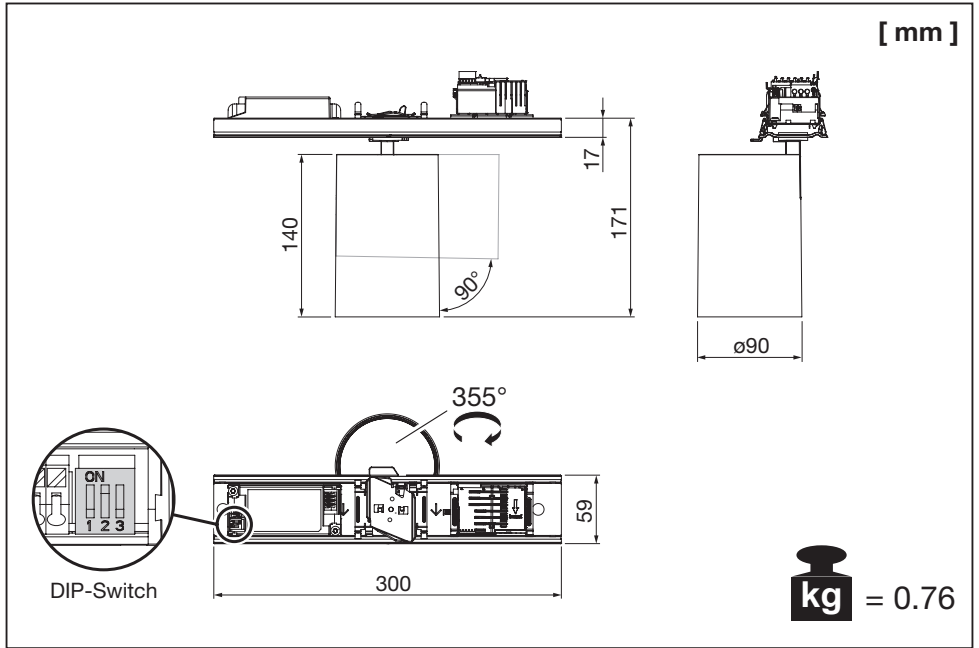

51SL...D...C

	L1 (1)	●→→→	L2 (2)	●→→→	L3 (3)		L' (4)		L'' (5)		R (6)		PE (7)
D2+ (8)		D1+ (9)		D2- (10)		D1- (11)		N (12)		N' (13)		N'' (14)	

51SL...M...C

	L1 (1)	●→→→	L2 (2)	●→→→	L3 (3)		L' (4)		L'' (5)		R (6)		PE (7)
D2+ (8)		D1+ (9)		D2- (10)		D1- (11)		N (12)		N' (13)		N'' (14)	

Die individuelle Auslegung der Elektroinstallation muss gemäß den Installationsrichtlinien IEC 60364 / DIN VDE 0100 erfolgen. Zudem sind die Einschaltströme, die Abschaltbedingungen für Schutzeinrichtungen (Schleifenimpedanz) und die Einhaltung des max. zulässigen Spannungsfalls zu beachten.

The individual design of the electrical installation must be realized in accordance with the installation guidelines IEC 60364 / DIN VDE 100. In addition, the switch-on currents, the switch-off conditions for protective devices (loop impedance) and compliance with the maximum permissible voltage drop must be observed.

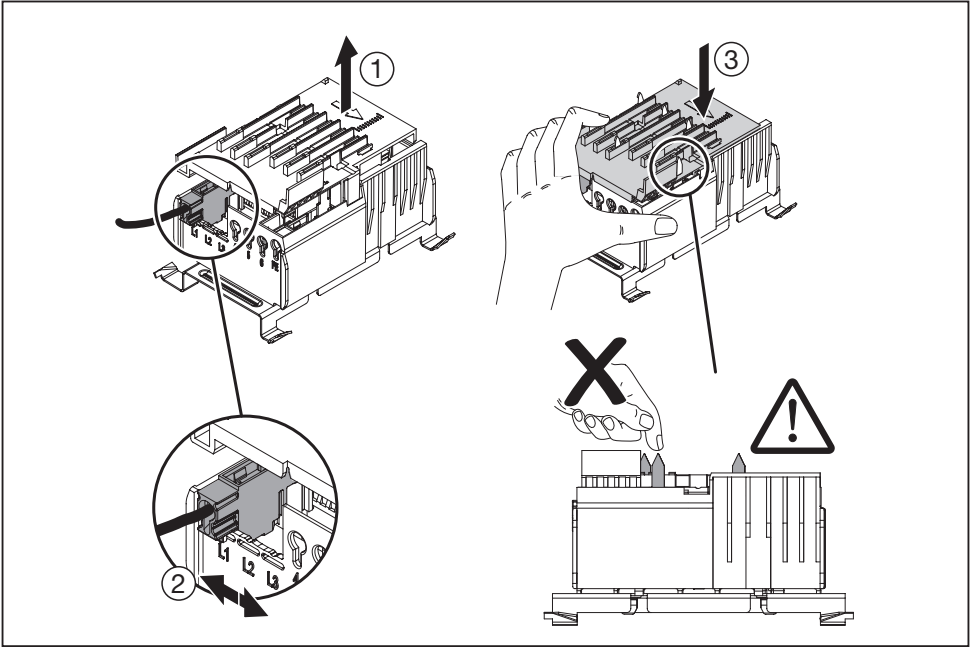

1 Umgebungstemperatur während der Installation: +5°C...+40°C
Ambient temperature during installation:

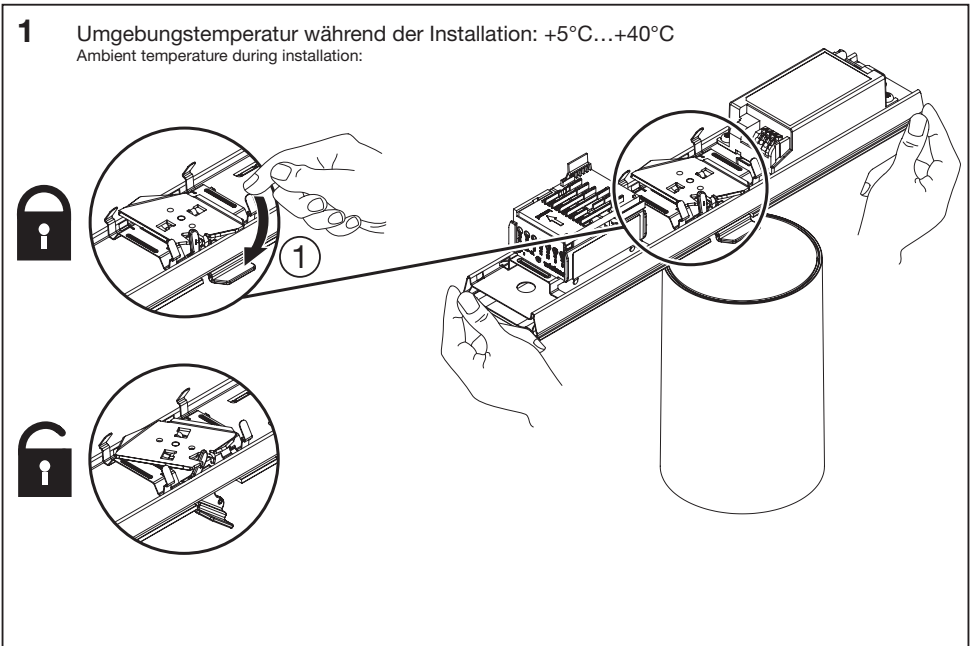

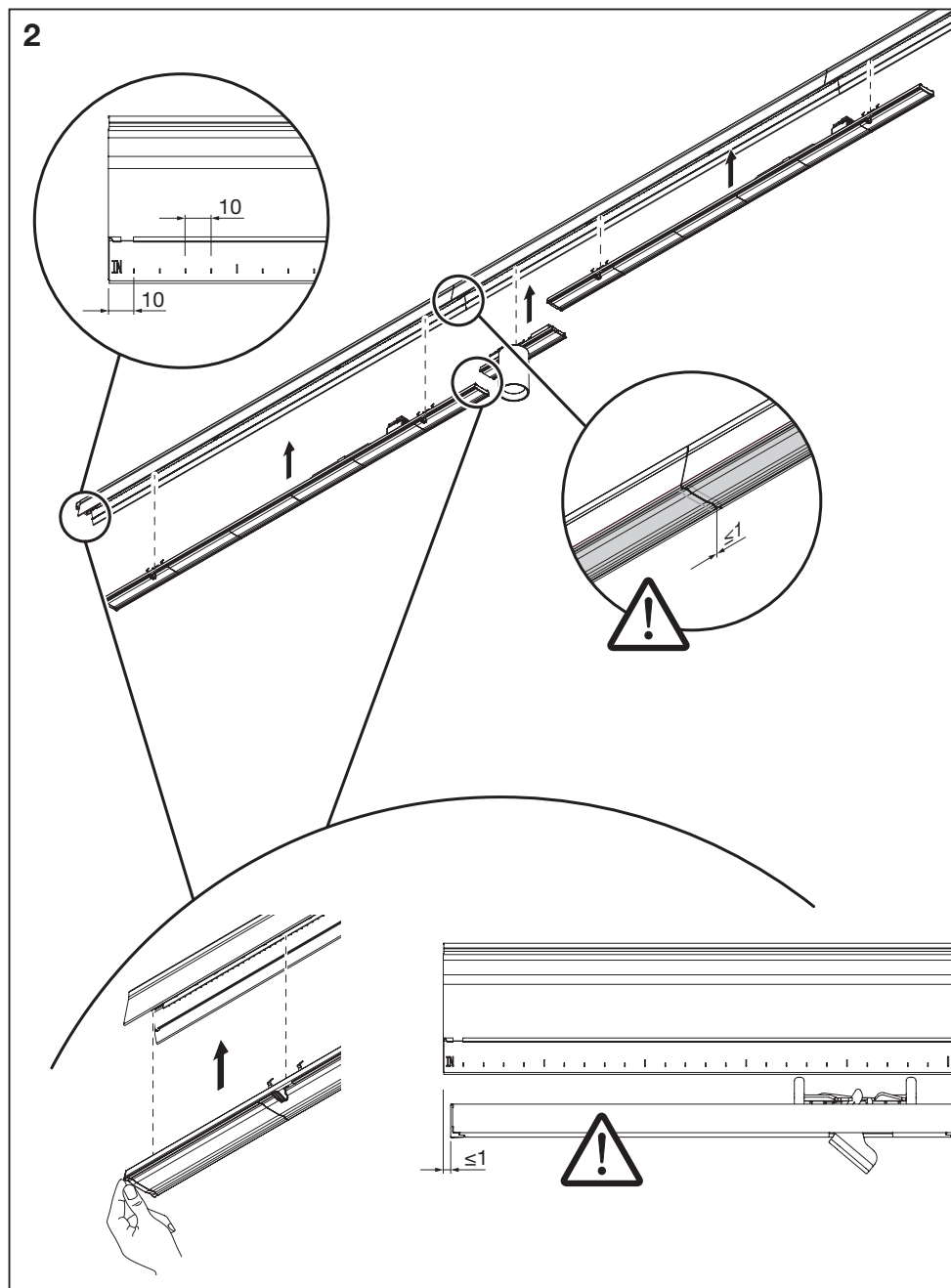

3

